

ROYAL CIVIL SERVICE COMMISSION

**BHUTAN CIVIL SERVICE EXAMINATIONS (BCSE) 2010
EXAMINATION CATEGORY: TECHNICAL**

**PAPER III: SUBJECT SPECIALIZATION PAPER for B.TECH & B. ENGG.
(COMPUTER SCIENCE & ENGINEERING)**

DATE: 24th November 2010

TOTAL MARKS: 100

TIME: 2.5 HOURS (150 MINUTES)

READING TIME: 15 MINUTES

INSTRUCTIONS:

1. Write your Roll Number clearly on the answer booklet in the space provided.
2. The first 15 minutes are being provided to check the number of pages, printing errors, clarify doubts and read the instructions. You are **NOT PERMITTED TO WRITE** during this time.
3. Use either **Blue** or **Black** ink pen or ball point pen for the written part and **H.B. Pencils** for the sketches and drawings
4. **All ANSWERS** must be written on the **ANSWER BOOK** provided. Candidates are not allowed to write anything on the question paper.
5. All answers must be labeled with appropriate question numbers (Section, Question and sub-Question Numbers wherever applicable). **Unlabelled answers will not be assessed.**
6. This question booklet consists of **10 pages** (including this page). It is divided into two sections, namely **SECTION A** and **SECTION B**.
7. **SECTION A** carries fifty (50) marks and consists of two (2) parts. **Part I** and **Part II**. **Answer all questions in this section.**

Part I consists of 30 multiple choices questions carrying one (1) mark each (30 marks).
Part II consists of four (4) short-answer questions of five (5) marks each (20 marks).
8. **SECTION B** carries fifty (50) marks containing two (2) case studies. Choose and answer **ANY ONE** case study.

**PART – A
(50 Marks)**

All answers in this section must be written on the Answer Book provided.

SECTION – I (30 Marks):

Multiple Choices: Select the most appropriate answer. There is only one correct answer in the list. Answers that contain more than one selection will not be graded. Choose only **ONE** answer.

Mark the correct answer letter (**a,b,c or d**) against the Question number in your **Answer Book**.

Example:

Q. Which of the following is the correct sequence of steps in the process of developing a computer program?

- a. flowcharting, pseudo-coding, algorithm development and coding
- b. coding, algorithm development, flowcharting and pseudo-coding
- c. pseudo-coding, algorithm development, coding, and flowcharting
- d. algorithm development, flowcharting, pseudo-coding and coding

Answer: Q – d

1. Which of the following mode is based on the direction of data transmission?

- a. Full-Duplex Transmission
- b. Synchronous Transmission
- c. Serial Transmission
- d. Parallel Transmission

2. With regard to database programming, which of the following is directly related to the attributes of the data?

- a. name of the Table
- b. number of Fields
- c. Field length
- d. Field type

3. The following digital circuit using NAND gates represents which output?

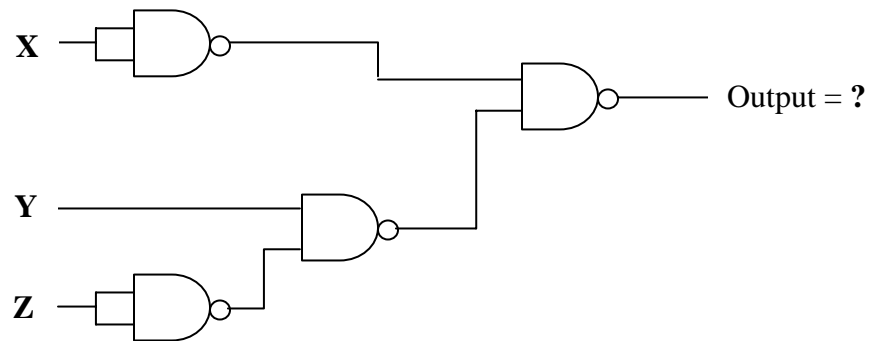

- a. $X' + Y + Z'$
- b. $X + Y'Z$
- c. $X'Y + Z'$
- d. $X + YZ'$

4. The following type of image is defined as a grid whose cells are filled with colour.

- a. bitmap
- b. vector
- c. printed
- d. interactive

5. Cookies that are stored on your computer's hard disk until they expire or you delete them are known as:

- a. session cookies
- b. persistent cookies
- c. first-party cookies
- d. third-party cookies

6. Technician A says that a Trojan Horse is a malicious program that can replicate itself, while Technician B says that a Worm is a program whose purpose is to create a backdoor to the infected system.

- a. Technician A is correct
- b. Technician B is correct
- c. Both Technician A and Technician B are correct
- d. Both Technician A and Technician B are incorrect

7. What is the compliment of the following Boolean expression?

$$AB + BC + AB$$

- a. $A' \cdot (B' + C') \cdot (A' + B')$
- b. $(A' + B) \cdot (B' + C') \cdot C'$
- c. $(A'+B') \cdot (B + C') \cdot B'$
- d. $(A' + B) \cdot (B' + C') \cdot (C' + B')$

8. Which of the following is NOT an example of a popular anti-virus program:

- a. McAfee
- b. Moodle
- c. PC-cilin
- d. Avast

9. In C++ Programming Language enum data type is associated with which of the following:

- a. encoding the data into binary code
- b. converting numbers into text
- c. putting data into order
- d. enumerating data into hex code

10. Which of the following is the key technique used for network convergence:

- a. convergence algorithms
- b. routing protocols
- c. shortest path first method
- d. address resolution protocol

11. Which of the following development tools are used in Software Engineering:

- a. Interactive Development Environment (IDE) Tools
- b. Decision Support System (DSS) Tools
- c. CAD Tools
- d. CASE Tools

12. Which of the following technology is deployed while designing processors for PCs:

- a. Hyper Threading
- b. Tunneling
- c. Micro Kernel
- d. VLSI

13. In the radio frequency spectrum, frequencies which are in the order of 30 MHz are categorized under:

- a. SHF – Super High Frequencies
- b. UHF – Ultra High Frequencies
- c. VHF – Very High Frequencies
- d. VLF – Very Low Frequencies

14. Which of the following is true regarding computer algorithms?

- a. an infinite sequence of steps in determining a solution to a problem
- b. is determined by the software platform
- c. is determined by the hardware specifications
- d. is subject to tracing and coding the solution

15. With reference to IP routing, which of the following methods is use to route IPv4 packets in an IPv6 network?

- a. encapsulation
- b. tunneling
- c. phishing
- d. masking

16. Which statement would be correct with regard to the following program?

```
int main()  
{  
    float compute(float, float) ;  
    -  
    -  
}  
void run (void )  
{  
    float a,b, r ;  
    cin >> a >> b ;  
    r = compute(a,b) ;  
}
```

- a. The function **compute()** can be invoked globally
- b. The function **run()** cannot invoke the function **compute()**
- c. The function **run()** can invoke the function **compute()**
- d. There are no errors and the code will run properly

17. Which OSI layer, in networking is concerned mainly with the file formats:

- a. data link layer
- b. transport layer
- c. presentation layer
- d. applications layer

18. Which of the following emerging technologies deals with pushing content to the user?

- a. mobile computing
- b. pervasive computing
- c. wearable computing
- d. ubiquitous computing

19. While using functional programming, the memory address of a variable is referenced by which of the following?

- a. call by reference
- b. call by address
- c. call by value
- d. call by type

20. Which of the following routing protocols use both vector-distance and link-state algorithms?

- a. Routing Information Protocol (RIP)
- b. Enhanced Interior Gateway Routing Protocol (EIGRP)
- c. Open Shortest Path First (OSPF)
- d. Border Gateway Protocol (BGP)

21. The following media requires signal repeaters at the shortest distance:

- a. multi-mode optical fiber
- b. shielded twisted pair
- c. unshielded twisted pair
- d. microwave transmission

22. A small self-contained program used within a web application is called:

- a. widget
- b. wiki
- c. midget
- d. gadget

23. A Disk drive where read/write control information is imbedded on the drive and thus not requiring a separate Disk Controller is known as:

- a. IDE Drive
- b. Scuzzy Drive
- c. Both a. and b.
- d. neither a. nor b.

24. Data in the working memory of PCs are usually stored in which of the following physical forms:

- a. LED's
- b. pits and lands
- c. polarized magnetic particles
- d. charged capacitors

25. Which of the following statement is incorrect with regard to operating systems:

- a. it is a system software
- b. it is a platform for applications
- c. it stores the bootstrap program
- d. it manages all the resources on the computer

26. Which of the following techniques maybe included in a Data Mining model:

- a. decision trees
- b. genetic algorithms
- c. neural networks
- d. meshed architecture

27. Which of the following wireless technology is generally used for last-mile connectivity in peri-urban and remote areas of difficult terrain?

- a. Wi-Fi
- b. WiMax
- c. WAP
- d. 3G

28. The term: 'Device Driver Programming', is associated with which of the following:

- a. Embedded System Design
- b. Shell Programming
- c. Assembly Language Programming
- d. Registry Design

29. Interface programs written using Java to connect applications to resources such as databases are known as:

- a. ActiveX controls
- b. Macros
- c. Applets
- d. Servlets

30. Secure Hash Algorithms (SHA) maybe employed by which of the following security features:

- a. WEP (Wireless Equivalent Privacy)
- b. Digital Signature
- c. Firewall
- d. Anti-Virus

SECTION- II (20 MARKS)

SHORT ANSWERS

All answers must be written on the **Answer Book** provided. Use only **blue** and **black** pens (ballpoint or fountain) for writing answers. All sketches and diagrams must be in **HB pencil**.

- 31. What do you understand by the term Software Quality Metrics? (1 Mark)**
Name four (4) metrics normally used and briefly describe each one of them. (4 Marks)
- 32. What is n-Tier Technology with respect to web services architecture? (2 Marks)**
For a 3-Tier architecture, briefly outline the functions and technologies that maybe used in each tier. (3 Marks)
- 1. What do you understand by the term GUI ?(1 Mark)**
Name three (3) devices and describe how they maybe employed for GUI. (3 Marks)
State an example of a non-GUI interface. (1 Mark)
- 34. With regard to Relational Database Model, what do you understand by the term decomposition? (1 Mark)**
Briefly describe each of the following: (4 Marks)
- a. Functional Dependency**
 - b. 3NF (Third Normal Form)**
 - c. 4NF (Fourth Normal Form)**
 - d. BCNF (Boyce-Codd Normal Form)**

**PART – B
(50 Marks)**

CASE STUDY

All answers in this section must be written on the Answer Booklet provided. Mark appropriate question numbers. Write answers with only blue/black ink/ballpoint pens. All diagrams and sketches must be done in HB pencils.

Answer ANY ONE (1) CASE Study. Each Case study carries 50 marks.

1. CASE STUDY: Bhutan Board Products Limited (BBPL) wants to go online.

You are an information technology (IT) consultant to Bhutan Board Products Limited (BBPL), a major particle board manufacturer and distributor. Its products include graded plain and pre-laminated particleboards and knockdown furniture. BBPL has been in business for over 30 years and sells more than Nu. 200 lakhs worth of board products each year to over 1000 customers. BBPLs customers are located all over the world, but most are in India and Bhutan.

Pema Wangdi, BBPL's director of sales has retained you to help him with a new marketing idea. He has read about other companies that have created Web portal sites for customers, and he is interested in developing a portal site that BBPL could operate with three other companies that sell products (such as timber, equipment, chemicals) and services (such as design, standardization, transportation and distribution) that are complimentary to BBPL products. The portal would provide BBPL customers with a Web site at which they could buy BBPL products, buy the products of three BBPL strategic partners, and obtain information about current trends in industrial design and technologies with regard to particle board products. The portal site would also include a second-hand furniture area in which BBPL customers could list used furniture for sale. Pema believes that giving customers a convenient way to liquidate old furniture will make it easier for his sales representatives to sell new products to those customers.

Pema has put together an internal team to examine the feasibility of the portal site, including key employees from BBPL Sales, Finance, Product Engineering, and IT Service departments. The team has identified several security and design issues which need to be finalized before deploying the portal. Pema would like you to help the team understand how the overall design (Web Service Architecture) should be done and also understand two security technologies, namely, digital certificates and encryption, and how these techniques might be used in BBPL's proposed portal site.

Required:

- a. Prepare a briefing report of about 200 words (excluding diagrams/sketches) for the BBPL portal team describing your overall design of the portal. The report should explain the technologies and describe applications/services that the portal is expected to provide.
- b. Prepare a Security report (about 200 words) for the portal team explaining i.) **digital certificates** and ii.) **encryption**. Report may include diagrams and sketches. Report should describe at least two applications on the portal where these technologies will be used.

2. CASE STUDY: Daejong Honda Motors Bhutan wants a Customer Information System.

Daejong Motors Bhutan specializes in selling new vehicles from Honda. The company advertises in local newspapers and also is listed as an authorized dealer on the Honda Web site and major web sites for auto buyers. The company benefits from good local word of mouth reputation and name recognition and is a leading source of Honda vehicles in Bhutan.

When a prospective customer enters the showroom, he or she is greeted by a Daejong sales representative who fills out a form with information such as the prospective customer's name, address, telephone number, date of visit, and model and make of vehicle in which he or she is interested. The representative also asks where the prospect heard about Daejong-whether it was newspaper ad, the Web, or word of mouth and notes this information down on the form.

If the customer decides to purchase an auto, the dealer fills out a bill of sale form, listing the vehicle identification number, vehicle make and model, colour, options selected, the base price, total price, and date of purchase along with purchaser's name, address and telephone number. Both forms are filed in manual folders – one for sales prospects and another for actual purchases.

Daejong does not feel it knows enough about its customers. It cannot easily identify repeat customers at its dealership and also cannot determine which prospects have made purchases. It also cannot identify which channels of advertising are working for them and also cannot tell which cars customers preferred most.

Required:

- a.** Prepare a systems analysis report detailing Daejong's problem, and a system solution that can be implemented using database management software. Your system analysis report should include the following:
 - i. Description of the problem and its organizational and business impact.
 - ii. Proposed solution, solution objectives, and solution feasibility.
 - iii. Cost and Benefits of the solutions you have selected. The company has few PCs, Internet access and full suite of desktop productivity tools.
 - iv. Information requirements to be addressed by the solution.
 - v. Management, organization and technology issues to be addressed by the solution, including change in business processes

- b.** On the basis of the requirements you have identified, design the database and populate it with few records per table. Show how the new system you have created use this database to generate queries and reports that would be of most interest to the Daejong management.